

Electrical Engineering and Information Technology

Title: *Modified Sagnac Loop Coherent Phase Modulated RF Photonic Link*

UMD18-09

Inventors: *Yifei Li, Ph.D.*

- Applications:**
- Antenna remoting
 - Radar front end
 - Radio-over-fiber link for 5G wireless communication antenna systems

- Benefits:**
- Eliminates random optical phase perturbation commonly found inside long optical fibers.
 - RF information is only encoded on one of the counter-propagating optical signals inside the loop.
 - Stable signal transmission over a 1 km optical fiber has been demonstrated.
 - Long distance fiber transmission showed no penalty to the noise and linearity performance (except for higher optical loss).

Technology Description: A RF/Photonic link is desirable to allow an antenna to be placed remotely from its signal processing unit. A coherent phase modulated link with an attenuating-counter-propagating optical phase locked loop (ACP-OPLL) photonic integrated circuit (PIC) demodulator has been proposed for this use, but such a system is sensitive to environmental perturbations and is not suitable for links of greater than 1 kilometer distance. Sagnac loop topology, where the phase fluctuations in clockwise and counter-clockwise propagating signal should cancel due to the symmetry, has been proposed as an alternative but has not previously been applied with a linear ACP-OPLL phase demodulator. This invention represents the first modified Sagnac loop coherent phase modulated RF/photonic link employing an ACP-OPLL optical receiver. Except for the optical loss due to the long fiber, no penalties in the link noise and linearity performance were observed through a 1 km fiber transmission.

Patent Status: US Patent Issued (10,790,911)

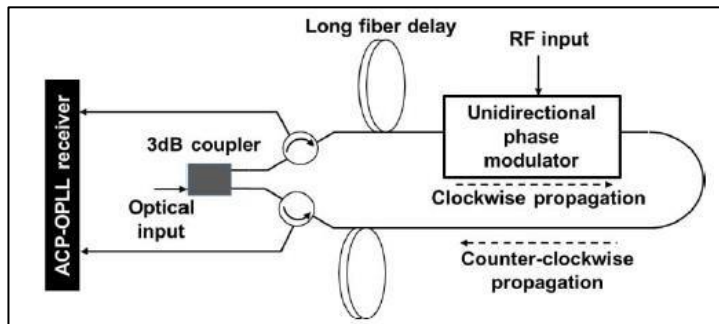

Modified Sagnac loop coherent PM RF photonic link, in accordance with the invention.

For more information:

Catherine Ives, PhD
Intellectual Property Consultant
 Office of Technology Commercialization & Ventures (OTCV)
 Foster Administration Building, #008
 University of Massachusetts Dartmouth
 285 Old Westport Road
 North Dartmouth, MA 02747
 Email: cives@umassd.edu

